

Specifications: Model 316(60) NPT Valve

Horizontal Flow

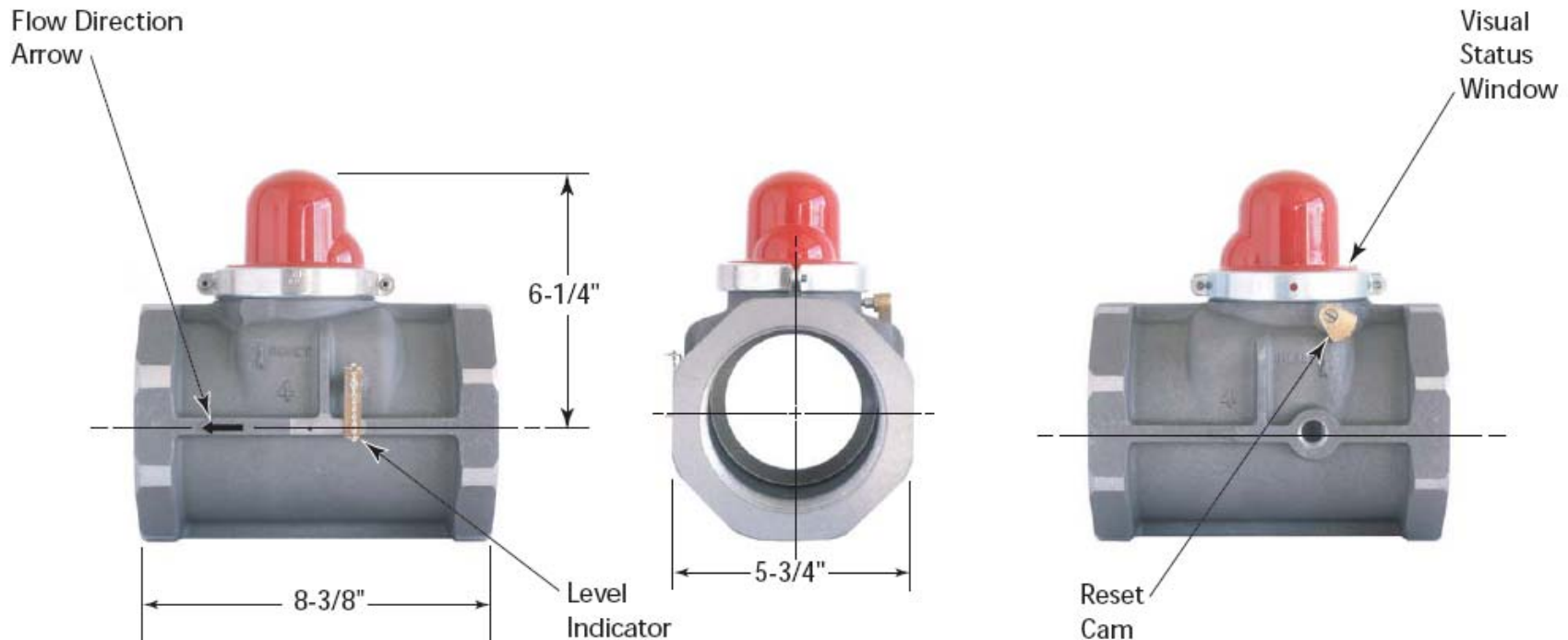

Valve Model#	CA-DSA No.	Length	Height	Octagon	Nominal Pipe Size	Threads Per Inch	APPLICATION	DATA
							Max. Pressure	Fuel
316	45R-113R	8-3/8"	6-1/4"	5-3/4"	4"	8	60 psi	Dry Fuel Gas

California Valves are UL-listed in the USA & Canada, certified by California's Division of the State Architect, Approved by Los Angeles, and warranted free of manufacturer's defects for 30 years (when used in the USA or Canada). California Valves meet California Standard 12-16-1 for Earthquake Actuated Automatic Gas Shutoff Systems & ASCE Standard 25-97 for Earthquake Actuated Automatic Gas Shutoff Devices.

Distributed by Strand Earthquake Consultants
Tel: (310) 473-2426 or 473-2316. Toll free: (800) 978-7263
Fax: (310) 473-1366. Website: www.strandearthquake.com
1436 S. Bentley Ave., Suite #6, Los Angeles, CA 90025 USA
Manufactured by Pacific Seismic Products, Inc.

4" Model 316 California Seismic Valve Threaded Horizontal

FLOW CAPACITY TABLE IWC/PSIG - Capacity S.C.F.H.

Merit Rating: Cv 480 (Equivalent Length of Pipe is 13 Feet)

For determining approximate values at selected natural gas pressures to 60 PSIG

Pressure Drop		8" iwc Inlet	14" iwc Inlet	3 psi Inlet	5 psi Inlet	7 psi Inlet	10 psi Inlet	20 psi Inlet	60 psi Inlet
PSI	IWC								
.0036	0.1	8,276	8,335	8,988	9,482	9,952	10,618	12,586	18,467
.0072	0.2	11,702	11,786	12,710	13,409	14,073	15,015	17,798	26,116
.0108	0.3	14,331	14,433	15,564	16,421	17,235	18,389	21,797	31,985
.0144	0.4	16,546	16,664	17,970	18,960	19,900	21,232	25,168	36,932
.0180	0.5	18,497	18,629	20,090	21,195	22,247	23,736	28,137	41,290
.0216	0.6	20,260	20,404	22,005	23,216	24,368	26,000	30,821	45,230
.0252	0.7	21,880	22,036	23,765	25,074	26,318	28,081	33,289	48,853
.0288	0.8	23,388	23,555	25,404	26,803	28,133	30,017	35,585	52,225
.0324	0.9	24,804	24,981	26,942	28,426	29,837	31,836	37,742	55,392
.0360	1.0	26,143	26,329	28,396	29,961	31,448	33,556	39,782	58,387
.0720	2.0	36,927	37,191	40,118	42,333	44,438	47,420	56,230	82,551
.1080	3.0	45,172	45,496	49,084	51,799	54,379	58,035	68,832	101,080
.1440	4.0	52,098	52,472	56,619	59,758	62,740	66,964	79,439	116,689
.1800	5.0	58,177	58,596	63,237	66,750	70,086	74,813	88,769	130,430



Horizontal Valves

		Sizes Available														Ambient Temperature
		NPT								Flanged						
		3/4"	1"	1 1/4"	1 1/2"	2"	2 1/2"	3"	4"	2"	2 1/2"	3"	4"	6"	8"	
Maximum Pressures of Available Sizes	7 psi	✓	✓	✓	✓											UL -40° to 150° F CA DSA: -10° to 150°F
	60 psi	✓	✓	✓	✓	✓	✓	✓	✓	✓	✓	✓	✓	✓	Fluid	
																Natural gas LP gas

Distributed by Strand Earthquake Consultants / Manufactured by Pacific Seismic Products, Inc.

Tel: (310) 473-2426 or 473-2316. Toll free: (800) 978-7263. Fax: (310) 473-1366. Website: www.strandearthquake.com